

ORDERING INFORMATION

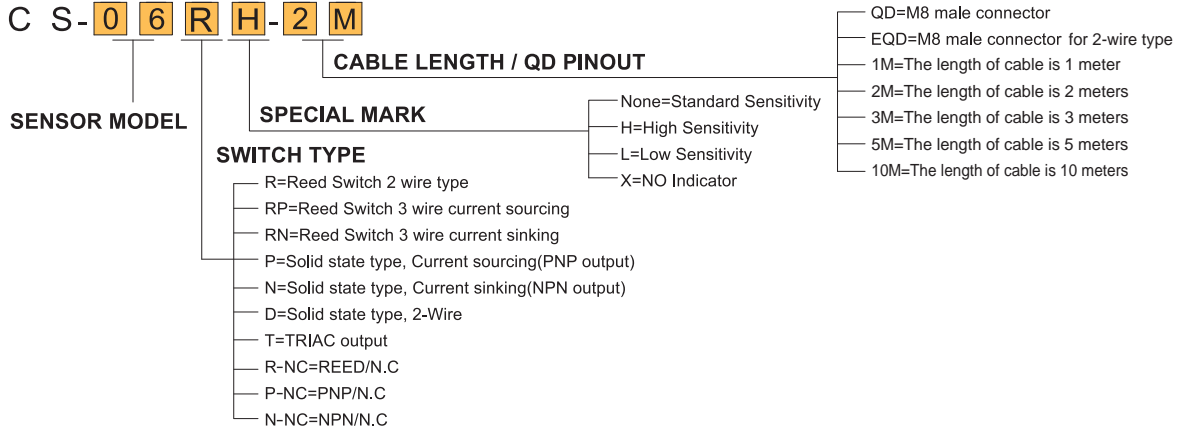

CONNECTION METHOD

2 wire sensor connection

▶ General connection

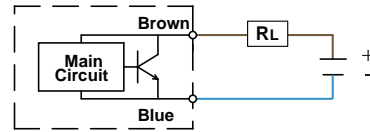
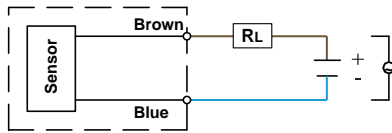

▶ Series Connection (AND)

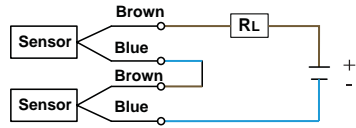

When connecting 2-wire sensors in series (AND), don't exceed more than two sensors due to the internal voltage drop (Typical V drop=2.5~4V per switch). Excessive Voltage drop will cause non-operation of the load.

▶ Parallel Connection (OR)

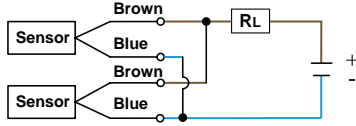

1. When connecting non-contact 2-wire sensors in parallel (OR), leakage current will increase and cause improper load operation.

2. When connecting 2-wire reed sensors in parallel(OR), possible concurrent operation will cause dim LED illumination due to lower current distribution.

3 wire NPN connection

▶ General connection

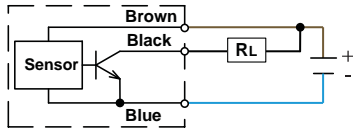

3 wire PNP connection

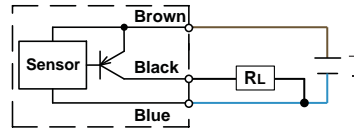

▶ Series connection (AND)

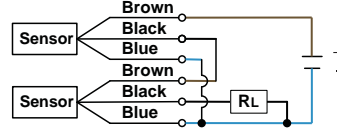
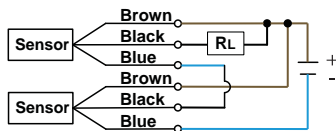

▶ Parallel connection (OR)

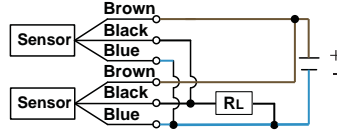
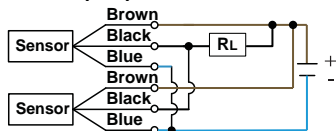

Reed SW. Type

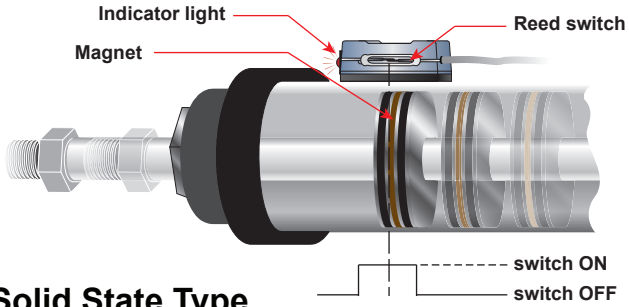

When the piston's magnet approaches the magnetic sensor, the internal reed switch will detect the change of magnetic field and close the contacts.

Solid State Type

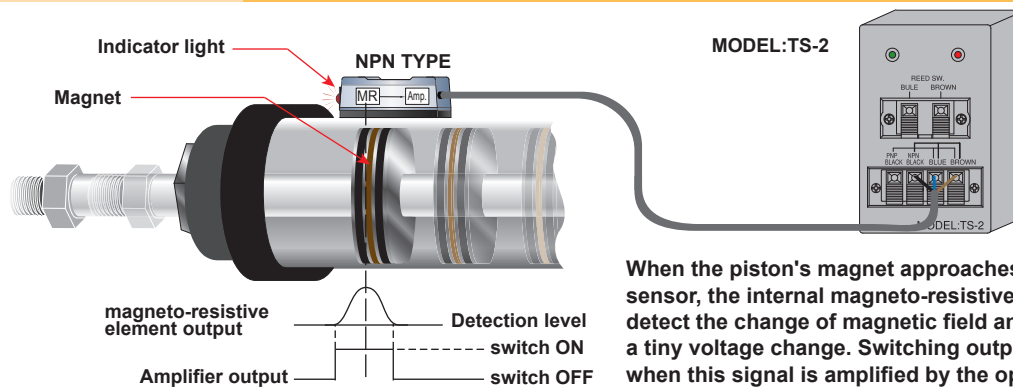

When the piston's magnet approaches the magnetic sensor, the internal magneto-resistive element can detect the change of magnetic field and cause a tiny voltage change. Switching output is achieved when this signal is amplified by the operation amplifier circuit in the magnetic sensor.

How to install the Magnetic sensor

▶ END OF STROKE DETECTION

STEP 1 Set the piston to the end of stroke position.

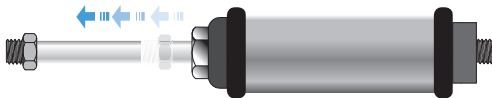

STEP 2 Slide the magnetic sensor forward and keep it close to the cylinder wall. Make a mark at the sensor turn-on point.

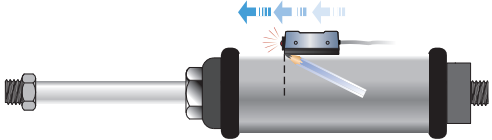

STEP 3 Slide the sensor forward continuously until the sensor turns off.

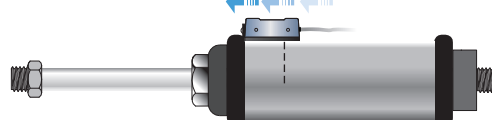

STEP 4 Slide the sensor backward until the sensor turns back on and make a mark.

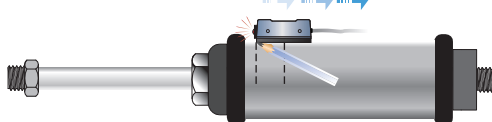

STEP 5 The intermediate position between the 2 marks will be the most ideal position.

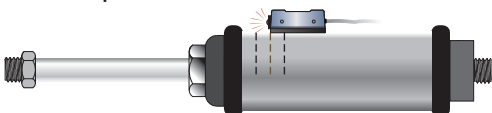

▶ INTERMEDIATE STROKE POSITION

STEP 1 Set the piston to the required position.



STEP 2 Slide the magnetic sensor forward and keep it close to the cylinder wall. Make a mark at the sensor turn-on point.

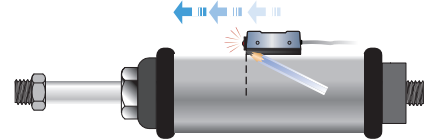

STEP 3 Slide the sensor forward continuously until the sensor turns off.

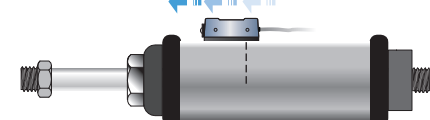

STEP 4 Slide the sensor backward until the sensor turns back on and make a mark.

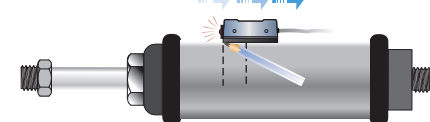

STEP 5 The intermediate position between the 2 marks will be the most ideal position.

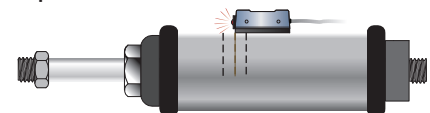

CAUTION

Magnetic Sensor

1. Do not exceed specification, permanent damage to the sensor may occur.

2. For reed switch type sensors, polarity must also be observed for the proper function of LED. Connect the brown wire in series with load positive (+) and the blue wire to negative (-) of power source. If the polarity is reversed, reed sensor remain functional but LED will remain "OFF" state.

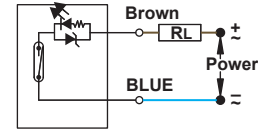

3. For solid-state type sensors, polarity must also be observed. Connect brown wire to the positive (+) and the blue to the negative (-) of DC power source. The black wire must connect to the load only. If the black wire is accidentally connected to the power source, permanent damage to the sensor may occur.

(NPN Output)

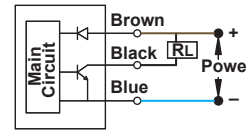

(PNP Output)

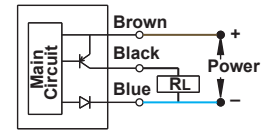

4. An external protection circuit may be required if the reed sensor is used with inductive load, such as relay or solenoid. For DC inductive load, attach an external diode parallel to the load and use R-C circuit parallel with AC inductive load as illustrated below.

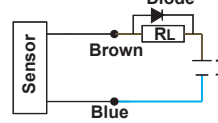

R: 2.7KΩ
C: 0.1uf/600V

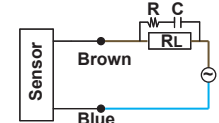

5. Keep sensors away from strong magnetic field to prevent malfunctions.

6. When using reed sensor with capacitive load or if the lead wire length exceed 10-meter, an inductor (560 ~ 1000 μH) or SR-1 (surge suppressor) must be installed in series with the sensor to prevent damage (Sticking effect).

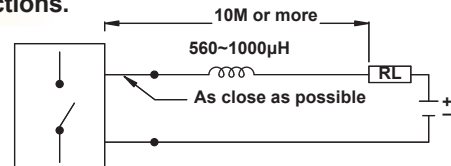

MODEL:SR-1 (Surge Suppressor)

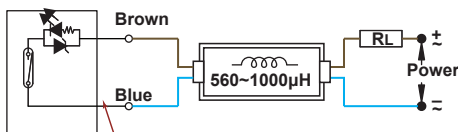

Connection cable between sensor and SR-1 must be as close as possible.

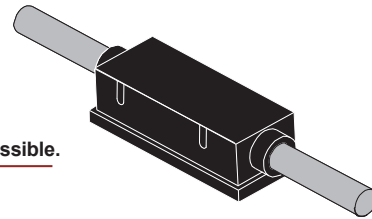

DIMENSION

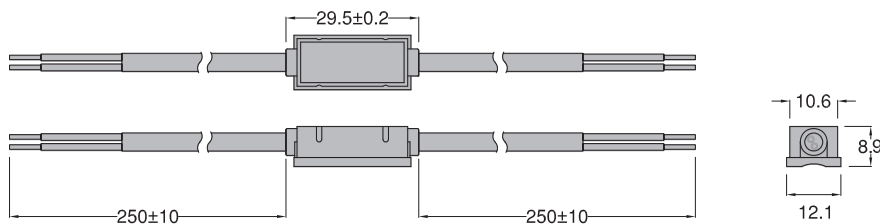

Unit:mm